



JEOTES[®]

PRESSURE VESSELS

JeoTes™ PRESSURE VESSELS

The accumulator tank, boiler, dirty separator, air eliminator, balance tank for heating systems and buffer tanks for cooling systems are mainly needed for district heating, cooling and hot water in leisure centers such as sports centers, malls and swimming pools, in military facilities, dormitories, apartments and mass housing.

For instant high requirements, storing hot water which is gained from plate heat exchanger provides comfort and ease to the user. Jeotes™ accumulation tank provides the heated water to be stored warm and to be kept ready for usage without heat loss. Except this, it is used in industrial plants and processes which consume larger amounts of heat and hot water.

Nowadays, usage of boilers is preferred especially for conditions where plate heat exchangers are not available. In these units, hot water is produced by coils or jackets and accumulated in volume of boilers itself.

A buffer tank is a storage tank used on the cold user side of an air-conditioning system. The tank is used as storage to cover peak loads or in situations when a surge in demand exceeds the capacity of the cooling system.

Air eliminators, removes air coming from water since temperature increases. Dirt separators are used for discharging of dirt particles and sediments for systems. For saving space because of equipment installations in lines, these two units can combine as one unit as package dirt and air separator. So, breakdown in metal equipments, troubles like cavitations in pumps, noise in pipes, low heating efficiency can be prevented.



GENERAL FEATURES

Automatic Control

The hot water storage and boiler tanks can be controlled with automatic controllers due to needs and requirements.

Insulation

The products are insulated with polyurethane, rock wool and glass wool against heat loss.

Long Life

Tanks are protected with cathodic protection against corrosion to have a longer life.

Thermostat Heater

If water in accumulation and boiler tanks will be heated with low-temperature heat sources or the final temperature of water that required is important and has to be precise, then thermostat heater can be used as additional.

Wide Usage Area

Tanks can operate with main water pressure. All ranges of temperature for water can be obtained if they are integrated to solid-fuel-gas boiler, solar energy, waste energy and cooling systems.

Aesthetic

Thus the outer coverage of the tanks is made of colored/brushed decorative steel or synthetic leather (vinyl), it has an aesthetic appearance.

Corrosion Protection

Interior surface which is in touch with water, are covered with anti-rust, titanium rich mixture of enamel or hot immersion galvanizing. Or it is manufactured from stainless steel. So it has high resistance to corrosion.



SEPERATORS

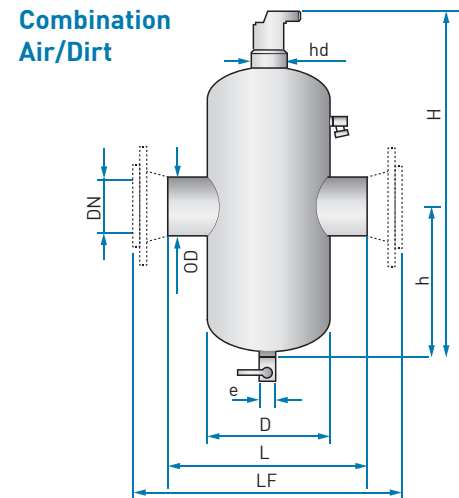
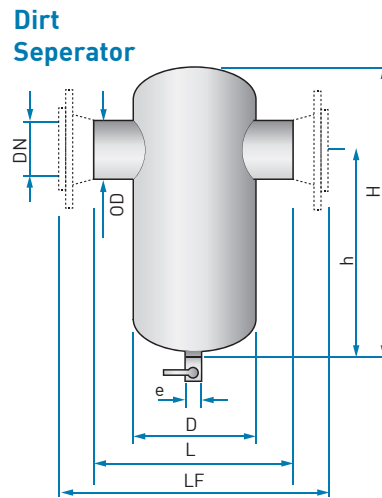
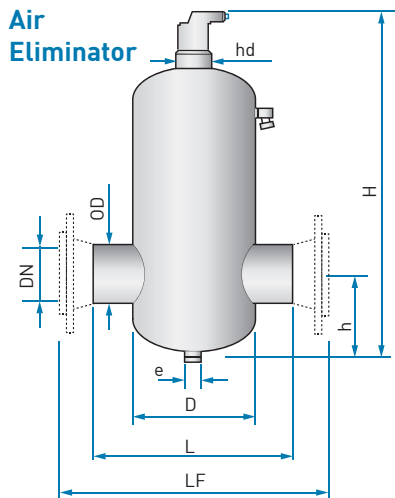

CAPACITY AND DIMENSION TABLE

DN	OD	D	e	L	LF	Air Eliminator			DirtSeparator			Combination Air/Dirt		
						H	h	V	H	h	V	H	h	V
mm	mm	mm	inç	mm	mm	mm	mm	lt	mm	mm	lt	mm	mm	lt
50	60,3	159	1"	260	350	470	115	5	395	270	5	630	265	7
65	76,1	159	1"	260	350	470	125	5	395	260	5	630	265	7
80	88,9	219	1"	370	470	590	150	17	515	355	17	785	345	25
100	114,3	219	1"	370	475	590	160	17	515	345	17	785	345	25
125	139,7	324	1"	525	635	765	205	50	690	475	50	1.045	480	75
150	168,3	324	1"	525	635	765	220	50	690	460	50	1.045	480	75
200	219,1	406	1"	650	775	975	275	105	900	615	105	1.315	615	150
250	273	508	2"	750	890	1.215	330	210	1.145	800	210	1.715	815	300
300	323,9	610	2"	850	1.005	1.430	385	350	1.360	955	350	2.025	970	500

Hydraulic Separators

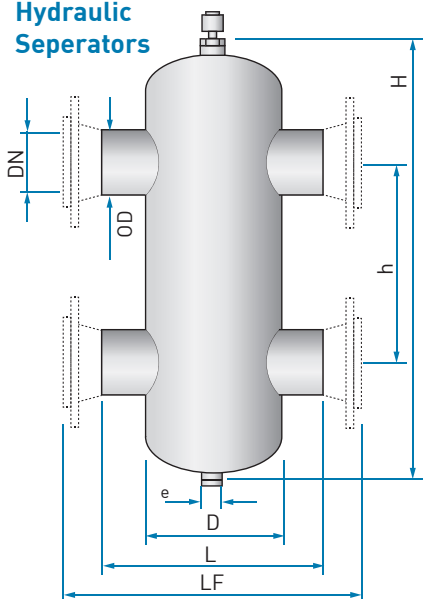

CAPACITY AND DIMENSION TABLE

Vessel Capacity	DN	OD	D	e	L	LF	H	h
kW	mm	mm	mm	inç	mm	mm	mm	mm
29	25	33,7	65	1/2"	180	240	370	250
43	40	48,3	80	1/2"	200	260	460	250
100	50	60,3	100	1"	220	300	600	350
140	65	76,1	125/150	1"	240/310	330/400	650/750	400/450
210	80	88,9	200	1"	420	500	950	600
395	100	114,3	200/250	1"	420/470	500/550	1100/1300	700/850
550	125	139,7	250	1"	470	550	1450	900
1300	150	168,3	300/350	1"	520/570	600/670	1670/1950	1100/1230
2500	200	219,1	400/450	1"	650/710	770/870	2200/2300	1400/1570
4500	250	273	450/650	2"	750/1000	890/1150	2600/2900	1800/2200
5500	300	323,9	700/750	2"	1150/1250	1400	3150/3300	2400/2600

BOILERS AND ACCUMULATOR TANKS

Single Serpentine Boiler

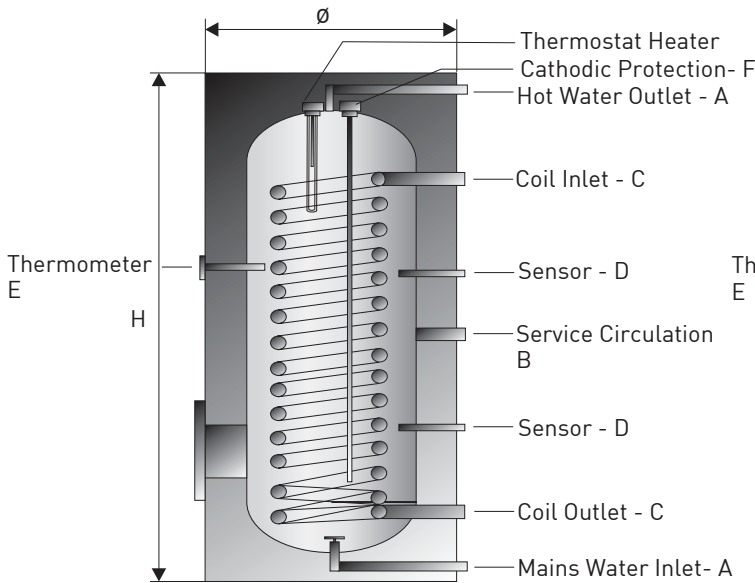

Double Serpentine Boiler

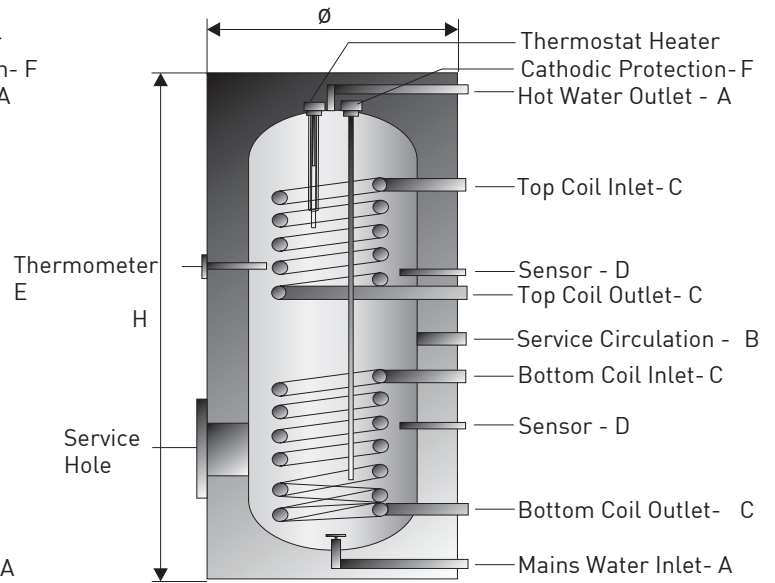

Jacket Type Boiler

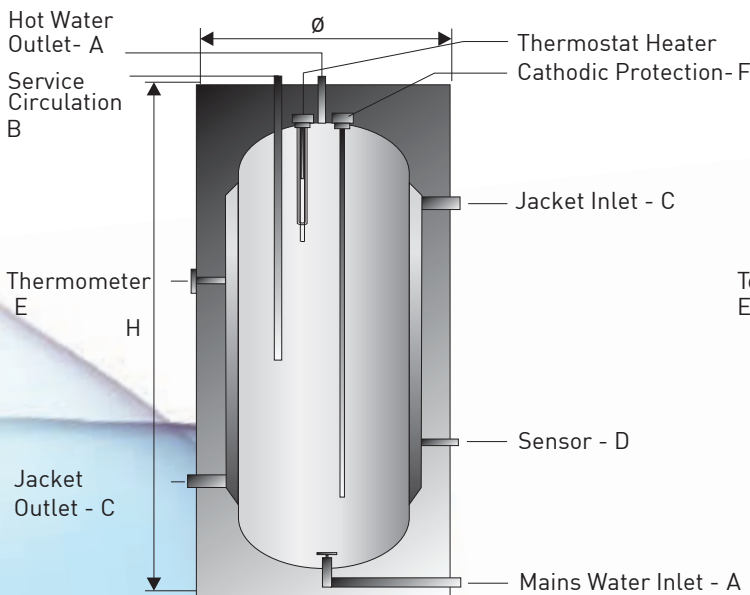

Accumulator Tank

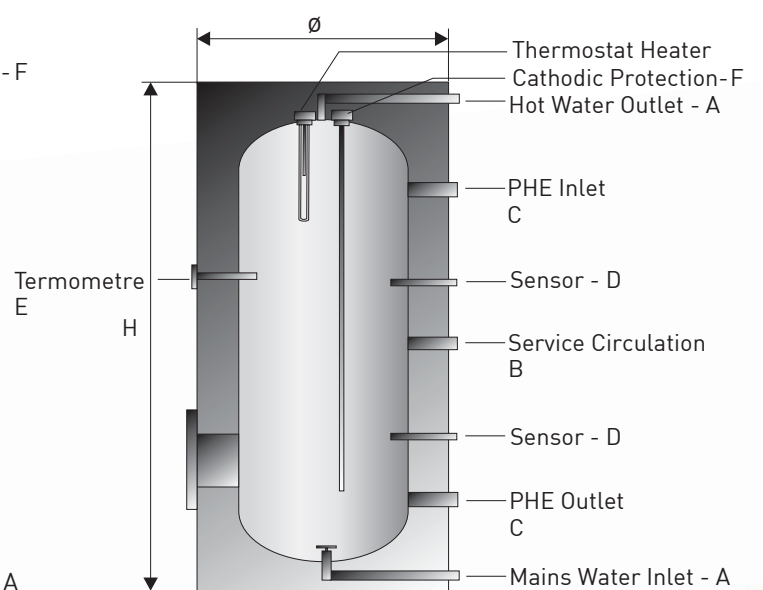

CAPACITY AND DIMENSION TABLE

Capacity	Diameter	Height	Inlet/Outlet					Cathodic Protection
V (lt)	Ø (mm)	H (mm)	A	B	C	D	E	F (mm)
100	500	1000	¾"	¾"	1"	½"	½"	700
160	550	1300	¾"	¾"	1"	½"	½"	700
200	600	1300	¾"	¾"	1"	½"	½"	700
300	650	1560	1"	1"	1"	½"	½"	700
400	780	1500	1"	1"	1"	½"	½"	700
500	780	1830	1"	1"	1"	½"	½"	1400
600	850	1700	1"	1"	1"	½"	½"	1400
750	900	1850	1 ¼"	1 ¼"	1"	½"	½"	1400
1000	990	2090	1 ¼"	1 ¼"	1"	½"	½"	1400
1250	1100	2250	1 ½"	1 ½"	1"	½"	½"	1400
1500	1300	2050	1 ½"	1 ½"	1"	½"	½"	1400
2000	1390	2190	1 ½"	1 ½"	1 ¼"	½"	½"	2800
2500	1600	2150	1 ½"	1 ½"	1 ¼"	½"	½"	2800
3000	1640	2190	2"	2"	1 ½"	½"	½"	2800
4000	1890	2200	2 ½"	2 ½"	2"	½"	½"	4200
5000	2090	2200	2 ½"	2 ½"	2"	½"	½"	4200

SPECIFICATIONS

Inner surfaces of products are coated with dye, titanium rich mixture of enamel or galvanize except stainless steel ones.

For preventing corrosion, in every tank there is magnesium anodic rod.

There is a thermometer on every product.

Thermostat heater in various heating capacities can be added, upon request.

As a standard, soft polyurethane is in use at products for insulation. Moreover, hard polyurethane insulation can be applicable.

Our products are manufactured by carbon steel, as a standard, and stainless steel upon request.

Outer coverage of products has dismountable protective synthetic leather. On the other hand, dyed/galvanized steel protection or production without insulation is possible.

As a standard, products are packed with bubble bags on wooden pallet.

Please send inquiry for out of standard production dimensions, insulations and covers and thermostat heater.

EXAMPLE INSTALLATION CHART

Single Serpentine Boiler

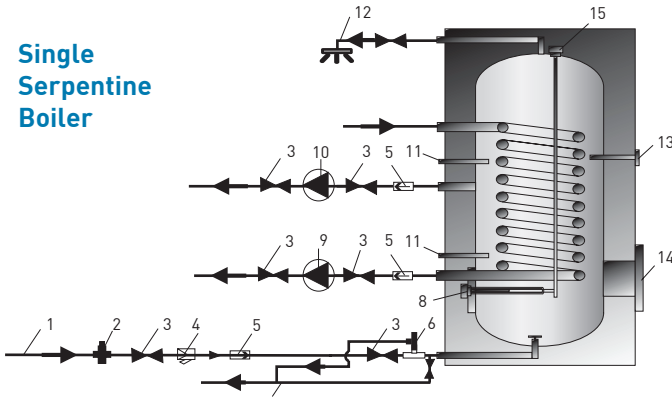

Double Serpentine Boiler

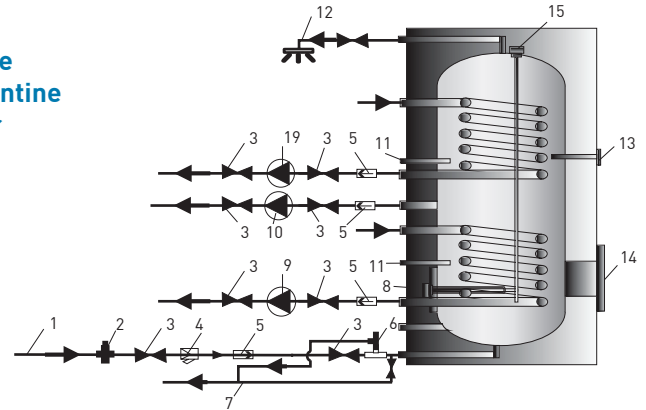

Jacket Type Boiler

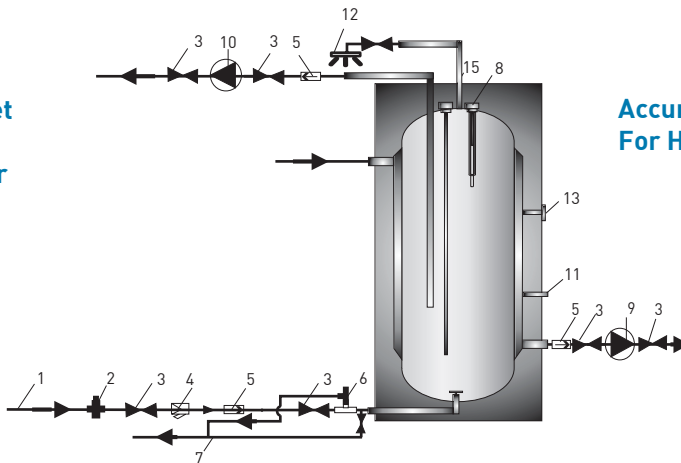

Accumulator Tank For Hot Water

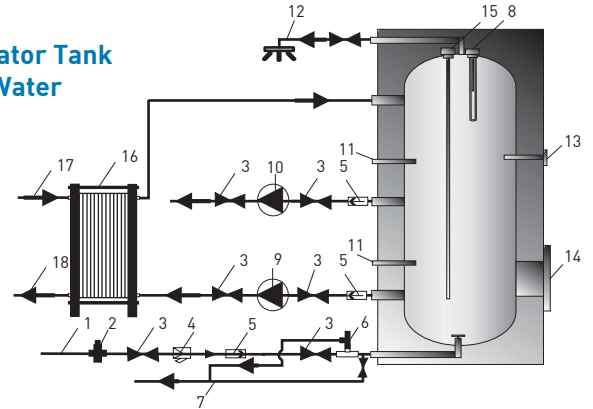

- 1- Mains water inlet
- 2- Pressure regulator
- 3- Service valve
- 4- Filter
- 5- Check valve
- 6- Safety valve
- 7- Discharge line

- 8- Thermostat heater
- 9- Circulation pump
- 10- Service circulation pump
- 11- Senson connection
- 12- Hot water outlet
- 13- Thermometer
- 14- Service Hole

- 15- Anodic protection
- 16- Plate heat exchanger
- 17- Heating source inlet
- 18- Heating source outlet
- 19- Second coil circulation pump

Accumulator Tank For Closed Loop System

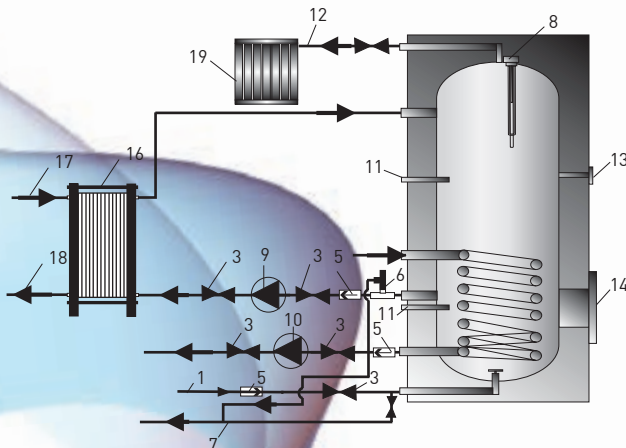

- 1- Kapalı devre suyu dönüşü (Ev ısıtma tesisatı dönüşü - İmalat proses suyu dönüşü)
- 2- -
- 3- Service valve
- 4- -
- 5- Check valve
- 6- Safety valve
- 7- Discharge line
- 8- Thermostat heater
- 9- Closed loop circulation pump
(Primary heat source circuit - Solar energy - Heat pump)
- 10- Closed loop circulation pump
(Secondary heat source circuit - Solar energy - Heat pump)
- 11- Senson connection
- 12- Closed loop hot water outlet
- 13- Thermometer
- 14- Service Hole
- 15- -
- 16- Plate heat exchanger
- 17- Heating source inlet
- 18- Heating source outlet
- 19- Radiator

BUFFER TANK

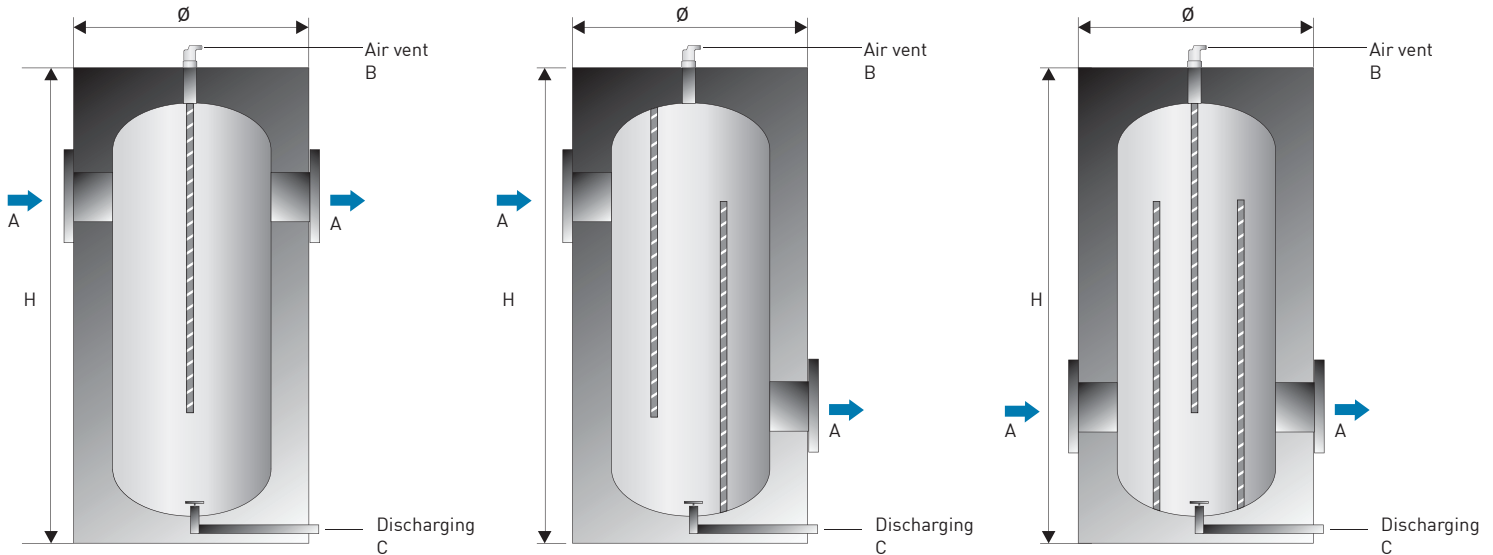

CAPACITY AND DIMENSION TABLE

Model	Baffle	Capacity	Ø D	H	Connections			Empty Weight
		Litre	mm	mm	A	B	C	kg
JTP-010	I	100	500	1050	DN32	1/2"	3/4"	60
JTP-030		300	700	1350	DN50	1/2"	3/4"	105
JTP-050		500	850	1450	DN65	1/2"	1"	180
JTP-075		750	850	2050	DN80	1/2"	1"	230
JTP-100	II	1000	950	2110	DN80	3/4"	1 1/4"	310
JTP-150		1500	1150	2000	DN100	3/4"	1 1/2"	480
JTP-200		2000	1250	2350	DN100	3/4"	1 1/2"	580
JTP-250		2500	1400	2350	DN125	3/4"	2"	670
JTP-300	III	3000	1400	2770	DN125	3/4"	2"	850
JTP-400		4000	1500	3150	DN150	3/4"	2"	1120
JTP-500		5000	1600	3070	DN150	3/4"	2"	1410

SPECIFICATIONS

Inner surfaces of products are coated with double anti-rust dye.

As a standard, 50 mm soft polyurethane is in use at products for insulation.

Outer coverage of products has dismountable protective synthetic leather.

As a standard, products are packed with bubble bags on wooden pallet.

Our products are manufactured by carbon steel, as a standard, and stainless steel upon request.

Please send inquiry for out of standard production dimensions, insulations and covers.



A: DES San. Sit. 117. Sk.
No:17 Ümraniye
İstanbul / TURKEY
T: +90 216 314 9001
F: +90 216 314 9009
E: info@jeotes.com
www.jeotes.com

